

"966*2970 +
"5203; 9
: 9

*Одобрено методической комиссией
мелиоративно-строительного факультета
27.05.2019 (протокол № 9)
и Научно-методическим советом БГСХА
29.05.2019 (протокол № 9)*

:"
" " "А. М. Брановицкий;
" " "А. Г. Мурашкин

" " "Л. Я. Степук;
" " "Н. Н. Гобралев

: 9
." 0 0
" " 0 " " 2 0 040 " "
" " - " " "1" 0 0 " "
0 0 " " "42420- 228 0" 0
ISBN 978-985-7231-31-7.

" " " " 0 " " "
" " " " " " " /
" " " - " 0 " " " /
" " 0 " " " " " " /
" " " " " " " 0 " "
" " " " " " " 0 " "
" " " " " " " " /
"3-96"27"23" " " " "3-96"28"26" "
" " " " 0

'964(075.8)
'5203 9

ISBN 978-985-7231-31-9 02) © " " " , 2020
ISBN 978-985-467-803-0

" " "*" " + " " " " 0
 " " " " "2000 0" " " " " "
 0 " " " " " " "
 " " " " " : 1 " /
 . 2 " " " " " "
 , 3 " " " " " , 4 "
 " " " " " " "
 " " " " 0 " " " "
 " " " " " " " "
 " " " " " " " 0 "
 " " " " " " " 0 "
 " " , " " " "3."5."7."8." :32 0

1.2.

2.301 8: " " "*" + " " /
 " " " " " " " /
 " " " " " 0 " " " "
 " " " " " " " /
 " " " " " 0 " " " "
 " " " " " " " 0 "
 " " " " " 2." " 1189×841 ." "
 " " 3 20 " " " " " "
 " " " " " " " " "
 0 " " " " " 2" " " 01.
 " " " " " 0 " " " /
 " " " " " 01.

1. "



	2	3	4	5	6
" ."	1189×841	841×594	594×420	420×297	297×210

"36: ×210 0 " " " " " 7" " "

1.5.

" " " " " " " " " " /
 Ø " 2.303 8: " " " " " " /
 " " " " " " " " " " /
 " " Ø " " " " " " " " /
 " " Ø " " " " " " " 04.

4. " " 2.303 68

1	2	3	4	5
1	"		$S = 0,5 \quad 1,4$	1. * 05, a; 5, 3; 5, u) 2. " " * 05, e) 3. " " * " " " " +* 05, e)
2	"		$S15 \quad S/2$	1. " " * 05, a) / 2. (05, a; 5, e) 3. (05, a; 5, e) 4. " " (05, a; 5, e; 5, ж; 5, u) 5. " " " / * 05, ж; 5, 3) 6. " " * 05, ж; 5, 3) 7. " " * 05, б) 8. " " " (+* 05, a) 9. " (05, 3; 5, u)
3	"		$S15 \quad S/2$	1. (05, a; 5, ж) 2. " "(05, a; 5, u)

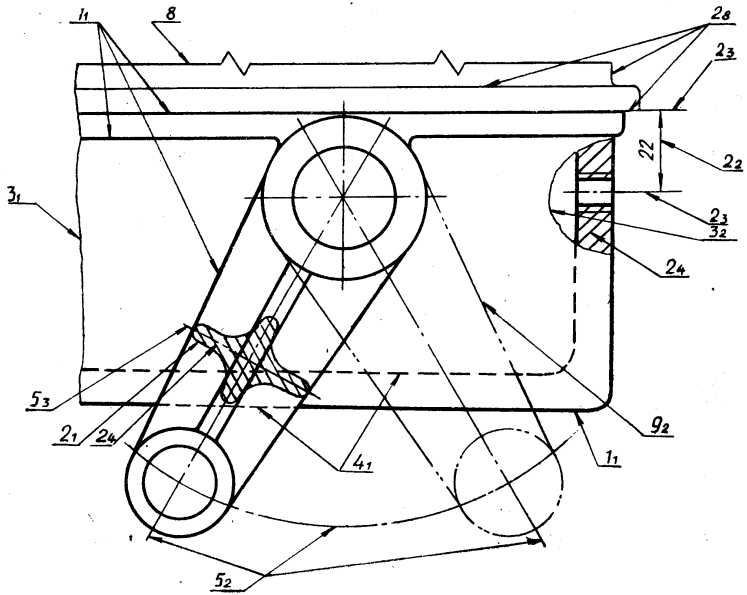

a

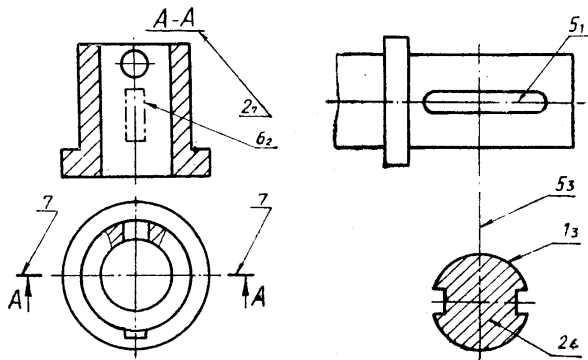

b

c

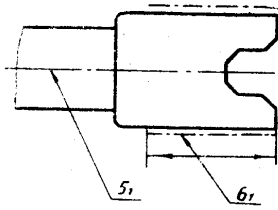

z

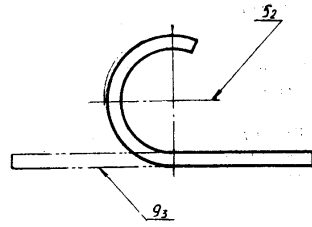

d

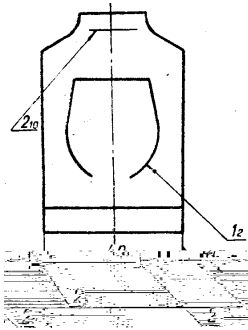

e

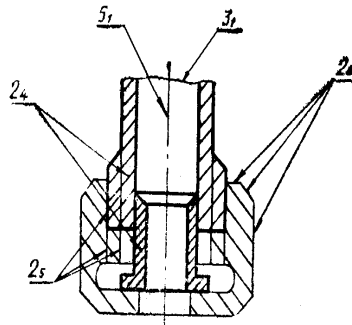

жс

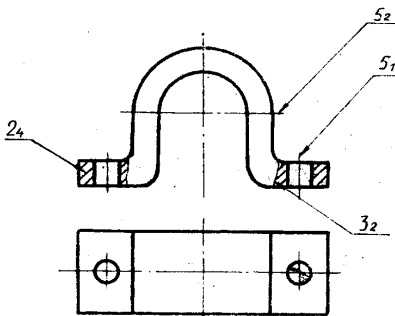

з

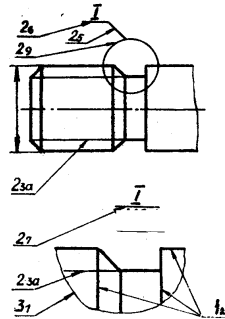

u

05. " " ;
 a 1, 2, 3, 4, 5, 8, 9; б 2, 6, 7; в 1, 2, 5; г 5, 6; д 5, 9;
 e 1, 2; жс 2, 3, 5; з 1, 2, 5; u 1, 2, 3, 5

АБВГДЕЖЗИЙКЛМНОПР

СТУФХЦЧШЩЪЫЬЭЮЯ

абвгдежзийклмнопрст

уфхцчшщъыьэюя

a

АБВГДЕЖЗИЙКЛМНОПР

СТУФХЦЧШЩЪЫЬЭЮЯ

абвгдежзийклмнопрст

уфхцчшщъыьэюя

б

07. " " " " :
а - " ; б -

" " " " " " 07. " " " " /
" " 08. " " " " " " /
, " 0

" "

1. " " " " " A " " A
2. " " " " " " " " " A
3. " " " " " " " A " " A
4. " " " " " " " " " A
5. " " " " " " " " " A
6. " " " A " " " " " A
7. " " " " " " " " " A
8. " " " " " " " A " " " "

" " A " " " " " " " "

9. " " " " " " " " " " "

A " " " " " " " " " " A "

10. " " " " " " " " " " " " A "

11. " " " " " " " " " " " " " "

" " " " " " " " " A " " " "

12. " " " " " " " " " " " " " " " "

" " " " " " " " " " " " " ?

13. " " " " " " " " " " " " " 0 "

14. " " " " " " " " " " " " " "

A " " " " " " " " " " " "

15. " " " " " " " " " " " " " "

16. " " " A " " " " " " " " " "

" " " A " " " " " " " " " " A "

17. " " " " " " " " " " " " " A "

18. " " " " " " " " " " " " " " " "

A " " " " " " " A " " " " " " " "

19. " " " " " " " " " " " " " " " A "

20. " " " " " " " " " " " " " " " A "

21. " " " " " " " " " " " " " " " A "

22. " " " " " " " " " " " " " " " A "

23. " " " " " " " " " " " " " " " " "

" A " " " " " " " " " " " " " " "

24. " " " " " " " " " " " " " " " A "

25. " " " " " " " " " " " " " " " /

" " " " A " " " " " " " " " "

26. " " " " " " " " " " " " " " " "

" " " " A " " " " " " " " " " "

27. " " " " " " " " " " " " " " " A "

28. " " " " " " " " " " " " " " " /

" " A " " " " " " " " " " " "

1.8. " " "

1.8.1. "

" " " " " " " " /
 4629 8: Ø " " " " " " " " /
 " " " " " " Ø " " " " " "
 " " " " " " Ø " " " " " "
 " " " " " S " " * 09, а, б, в). /
 " " " " " " " " " " /
 " " " 67°.

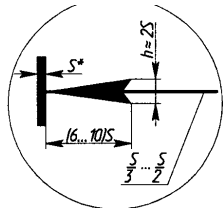

*Толщина основной линии

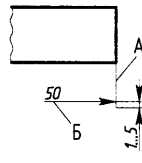
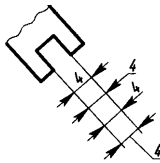

а

б

в

09. " " " " " " " " :

а " " " " " " = " =
 б " " " " " " =
 в " " : А ; Б

" " " " " " " * " " /
 " Ø " " " " " " " " " "
 " S15 S140 " " " " " " " " "
 " " " " " " " " " " 0 /
 " " " Ø " " " " " " " " /
 " " 8 32 " " " " " " " " /
 " " Ø " " " " " " " " " "
 " " Ø " " " " " " " " " "
 " " " 3 7 Ø " " " " " " "
 " " " " " " " " Ø " " /
 " " " " " " " " " " /

" " " " " " " " /
 " " " " " " " 0 " " "
 " " " " " " " 0 " " "
 " " " " " " " " " "
 " " " " 012, 13).

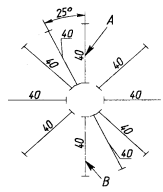
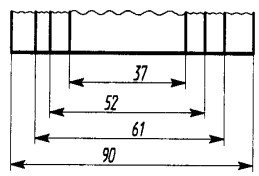
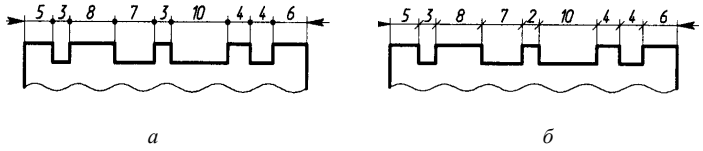

012. " " " :
 a, b " " =8 " " ;
 2 " " " " "

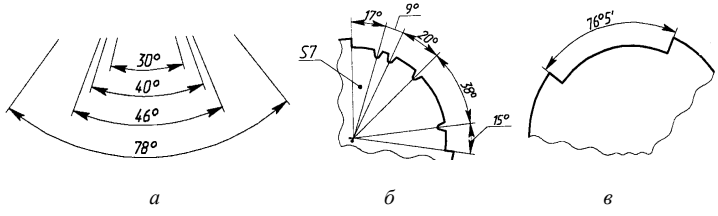

013. " " " :
 a " " " =
 b e " " " (S7 " ");

" " " " * " 30° " "
 " " - " * 014).

1.8.3.

" " " " " " " " " " Ø
 " " " " * "+" " " " " " /
 " " " " " " " " " " 0
 " " " " " " " " " " "
 " " " * 025, a+" " " " " "
 " * 025, б+" " " " " " "
 " × (") * 025, в).

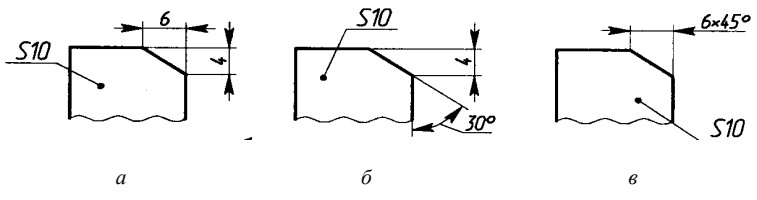

025. " " " "a" " " =
 б " " " " =в

" " " " * "+" " " " " "
 " " " " " " " " " " "
 " " " " " " " " * 026, a+" "
 " " " " " " " * 026, в+Ø " " /
 " " " 0

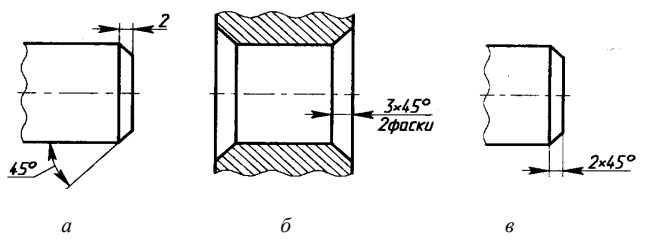

a, в " " 026. " " "
 б " " " " "

" " " " " " " " " /
 " " " " " " " " * 026, б).

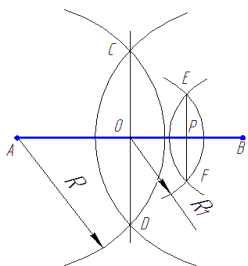

a

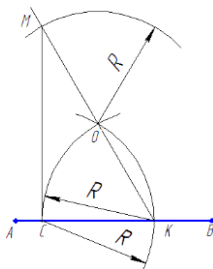

б

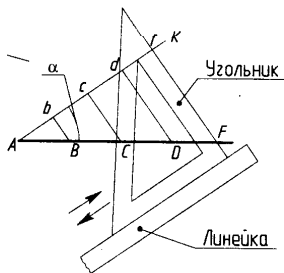

в

032.
 а " " " " =
 б " " " " =
 в " " " " "

19.4.

" " " " " " " "
 " " " " " " " "
 " " 0 " " " " " "
 " " " " " " " " /
 " " " " " " " " /
 " " " " " " " " /
 " " " " " " " " /
 " " " " " " " " /
 0 " " 09" " " " /
 " "4 16 0 " " " "

7. " " "

2	1,000	7	0,434	12	0,258
3	0,866	8	0,383	13	0,239
4	0,707	9	0,342	14	0,223
5	0,588	10	0,309	15	0,208
6	0,500	11	0,282	16	0,195

" " " " " " " /
" " " " " " " " " " " "

" " " " " " " " " " " "
" " " " " " " " " " " "

0 3 3 0 " " " " " " " " " " " "
" " " " " " " " " " " " " " " "

" " " " " " " " " " " " " " " "

" " " " " " " " " " " " " " " "

" " " " " " " " " " " " " " " "

0

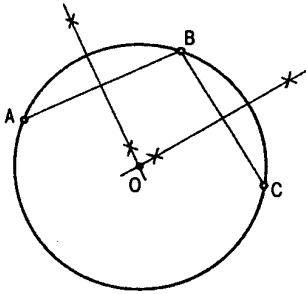

a

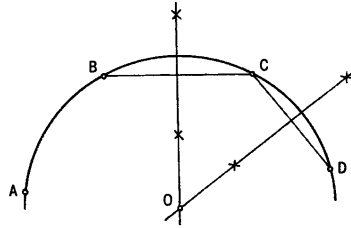

b

033. " "

" " " " " " " " " " " /
" " " " " " " " " " " /
" " " " " " " " " " " " " " " "
" " " " " " " " " " " " " " " "

"* 034, *a, b*). " " " " " "

" " " " " " " " " " " "

0

" "

1. " " " " " A
2. " " " " A
3. " " " " " A "
4. " " " " " " " /
5. " A " " " " " "
6. " " A " " " " " A
7. " " " " " " " " " /
8. A " " " " " A
9. " " " " " " A
10. " " " " " " " /
11. " A " " " " " " " "
12. " A " " " " " " A
13. " " " " " " " A
14. " " " " " " " A
15. " " " " " " " A
16. " " " " " " " " A
17. " " " " " " A
18. " " " " " " " " /
19. " " " " " " " 0 " " "
20. " 0 " " " " " " " ?
21. " " " " " " " " " "
22. " A " " " " " " " /
23. " " " " " " " " 0 A
24. " " " " " A " " " " "
25. " " " A " " " " " "
26. " " " " " " " " " A
27. " " " " " " " " " /
- A " " " " " A

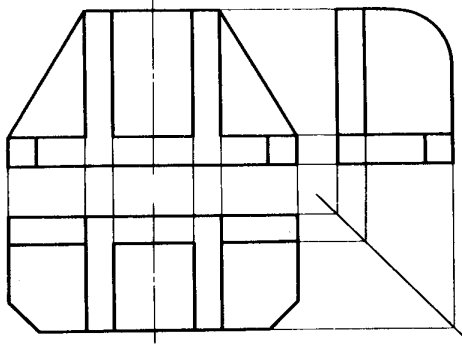

045. " " (3 +

" " " " " " " " " " " " /
 " " " * 046).

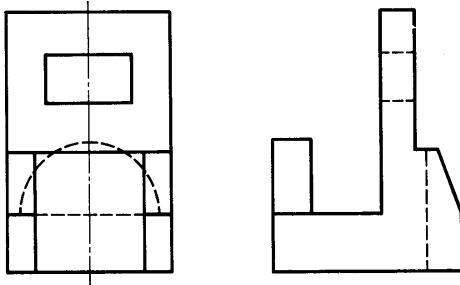

046. " " 4 +

" " " " " " " " " " " 0 0
 " " " " " " " " " " " 0
 * " " " " " " " " " " * /
 +0 " " " " " " " " " " 0 0 " "
 * 049+0 " " " " " " " " " " /
 " 0 " " " " " " " " " 048.

* " " " " " " + /
 " " 0

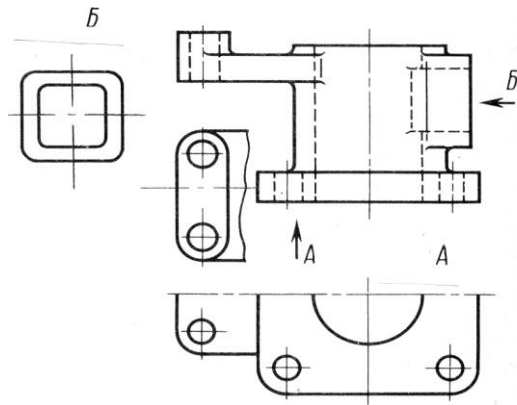

051. " " " "
 A " " " " =
 B " " " " "

2.1.2.

" " " " " " " "
 " " " " " " " " "
 " * 054+0 " " " " " " " " /
 " " " " " " " " " " " "
 " " " " " 0 0 " " " " 0 " "
 * + " " " " " " " " " " "
 " " " " " " " " " " " " 0 /
 " " " " " " " " " " " " " " /
 " " " * +0 " " " " " " " " " " "
 " " " " " " " " " " " " " " " /
 " " " " " " " " " " " " " " 0 " "
 " " 0 " " " " " " " " " " " " /
 " " " " " " " " " " " " " " " " * 052), /
 " " , " * 053). /

" " " " " " " " " " /
 " " " " " " " " " " /
 " " " " " " " " " " /
 " * 052 56+ " " " " " " " /
 " * 055), " " " " " " " /
 " * +0 " " " " " " " /
 " " " " " " " " " " /

055, б.

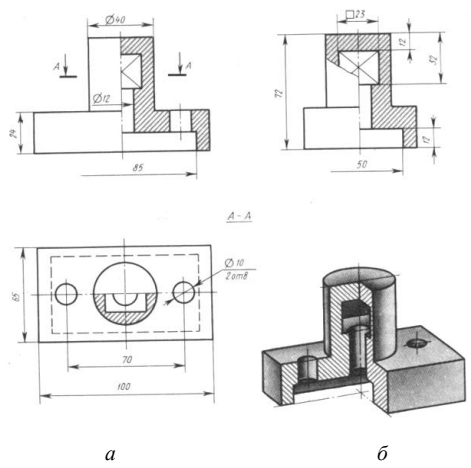

a б

055. " :
 a - " ; б - "

" " " " " " " " " /
 " " " " " " " " " /
 " " " " " " " " " /
 " " " " " " " " " /
 " " " " " " " " " /
 " " " " " " " " " /
 " " " " " " " " " /
 " " " " " " " " " /
 " " " " " " " " " /
 " " " " " " " " " /
 " " " " " " " " " /
 " " " " " " " " " /
 " " " " " " " " " /
 " " " " " " " " " /
 " " " " " " " " " /
 " " " " " " " " " /
 " " " " " " " " " /
 " " " " " " " " " /
 " " " " " " " " " /
 " " " " " " " " " /
 " " " " " " " " " /

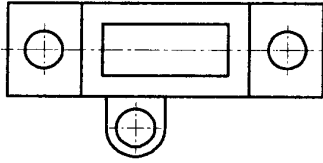
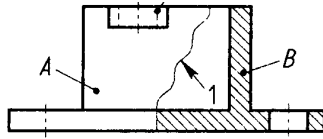

a

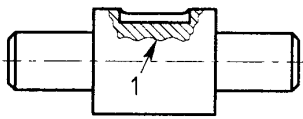

б

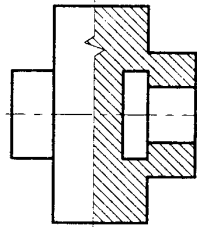

в

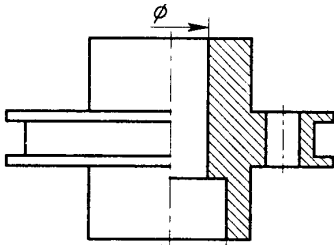

г

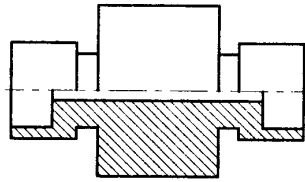

д

059.

a-	"	"	"	"	"	"	"	"	"	"	"	"
б-	"	"	"	"A	"B	"I	"	"	"	"	"	"
в-	"	"	"	"	"I	"	"	"	"	"	"	"
г-	"	"	"	"	"	"	"	"	"	"	"	"
д-	"	"	"	"	"	"	"	"	"	"	")

2.1.3.

" " " " " " " " " " " " " " " " "
" " " " " " " " " " " " " " " " "
" " " " " " " " " " " " " " " " "
" " " " " " " " " " " " " " " " "
" " " " " " " " " " " " " " " " "
" " " " " " " " " " " " " " " " "
" " " " " " " " " " " " " " " " "

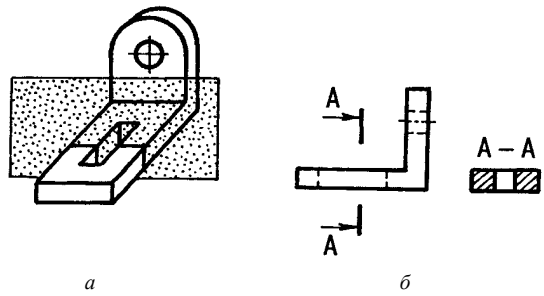

a - " 060. " - " "
" - " " = " - " "

" " " " " " " " " " " " " " " / "
" " " " " " " " " " " " " " " / "
" " " " " " " " " " " " " " " " "
" " " " " " " " " " " " " " " "

* 061).

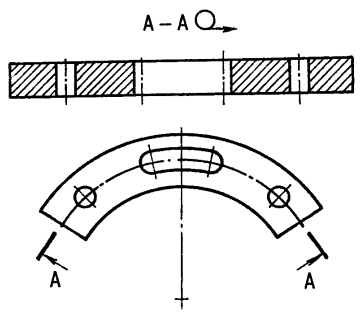

061. " " "

" 0 " " " " " " /
 " " " " " " " " * " ±" /
 " 0 0 " " " " " " " " /
 " " * 064). " " " " " " 060, 61.

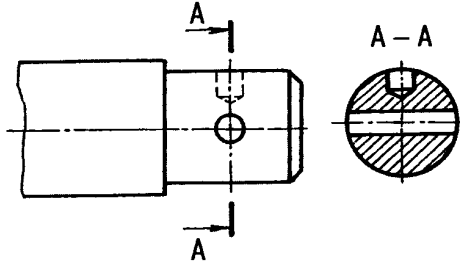

064.

" " " " " " " " " " " " /
 " " " " " " " " " " " " /
 (0 062, a[±] " " " * 0 063, a), " " " /
 " " " " " " " " " " " " /
 " " " " " " " " " " " " /
 " " " " " " " " " " " " * 065).

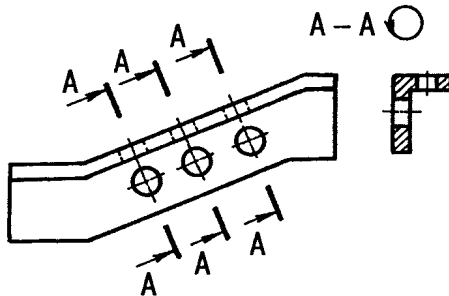

065.

" " " " " " " " " " " " /
 "[1, 3, 4, 10].

2.1.4.

" " " - " " " - " " " " " /
 " " " " " " " " " " " /
 " " " " " " " " " " 0 " /
 " " " " " " " " " " " /
 " " " " " " " " " " " " /
 " " " " " " " " " " " " /

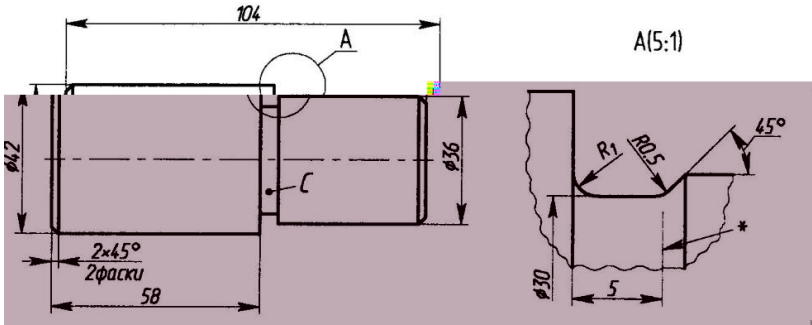

066. " " " "C -

" " " " " " " " " /
 " " " " " " " " " /
 " " " " " " " " " /
 " " " " " " " " " /
 " " " " " " " " " /
 " " " " " " " " " /
 " " " " " " " " " /
 " " " " " " " " " /
 " " " " " " " " " /

2. " " " A' " " " " /
 A' " " " A " " " " " /
 3. " " " " " " " A
 4. " " " " " " A
 5. " " " " " " A' " " "
 " " " " A " " " " /
 6. " " " " A' " " " " " /
 " A " " " " " " " A
 7. " " " " " " " " " A
 8. " " " A' " " " " " " "
 " A " " " " " " " " /
 9. " " " " " " " " " /
 A " " " " " A' " " " /
 10. " " " A " " " " " " /
 " " " " " " " " " A
 11. " " " " " " " " " A
 12. " " " " " " " " " " A
 " " " " " " " " " " /
 " A " " " " " " " " /
 13. " A " " " " " " " " /
 " " " " " " " " " " "
 14. " A " " " " " " " " "
 " A " " " " " " " " " /
 15. " " " " " " " " A' " " " /
 " " " " " A " " " " " /
 16. " " " " " " " " " " " " /
 A' " " " " " " " " A " " A
 17. " " " A' " " " " " " A
 18. " " " " " " A " " " /
 " " " A " " " " " " /
 19. " " " A' " " " " " " /
 " " " " " " " " A
 20. " " " " " " " " A
 21. " " " " " " " " " " /
 " " " " " " " " A' " /
 " " " " " " " " A
 22. " " " " A " " " A A
 23. " " " " " " " " A

2.2.

"	"	"	"	"	"	"	"	"	"
"	"	"	"	"	"	"	"	"	"
"	"	"	"	"	"	"	"	"	"
"	"	"	"	"	"	"	"	"	"
"	"	"	"	"	"	"	"	"	"
"	"	"	"	"	"	"	"	"	"
"	"	"	"	"	"	"	"	"	"
"	"	"	"	"	"	"	"	"	"
"	"	"	"	"	"	"	"	"	"
"	"	"	"	"	"	"	"	"	"
"	"	"	"	"	"	"	"	"	"
"	"	"	"	"	"	"	"	"	"
"	"	"	"	"	"	"	"	"	"
"	"	"	"	"	"	"	"	"	"
"	"	"	"	"	"	"	"	"	"
"	"	"	"	"	"	"	"	"	"
"	"	"	"	"	"	"	"	"	"
"	"	"	"	"	"	"	"	"	"
"	"	"	"	"	"	"	"	"	"
"	"	"	"	"	"	"	"	"	"

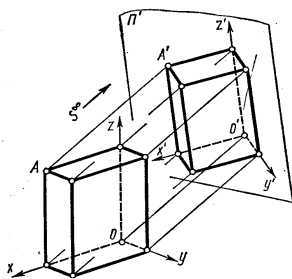

067.

"	"	"	"	"	"	"	"	"	"
"	"	"	"	"	"	"	"	"	"
"	"	"	"	"	"	"	"	"	"
"	"	"	"	"	"	"	"	"	"
"	"	"	"	"	"	"	"	"	"
"	"	"	"	"	"	"	"	"	"
"	"	"	"	"	"	"	"	"	"
"	"	"	"	"	"	"	"	"	"
"	"	"	"	"	"	"	"	"	"
"	"	"	"	"	"	"	"	"	"
"	"	"	"	"	"	"	"	"	"
"	"	"	"	"	"	"	"	"	"
"	"	"	"	"	"	"	"	"	"
"	"	"	"	"	"	"	"	"	"
"	"	"	"	"	"	"	"	"	"
"	"	"	"	"	"	"	"	"	"
"	"	"	"	"	"	"	"	"	"
"	"	"	"	"	"	"	"	"	"
"	"	"	"	"	"	"	"	"	"
"	"	"	"	"	"	"	"	"	"
"	"	"	"	"	"	"	"	"	"
"	"	"	"	"	"	"	"	"	"

2.2.1.

" " " " "
 " " " " " " " "
 " " " " " " " "
 " " " " " " " "
 " " " " " " " "
 " " " " " " " "
 " " " " " " " "
 " " " " " " " "
 " " " " " " " "
 " " " " " " " "
 " " " " " " " "
 " " " " " " " "

"342 "»: 068, a).

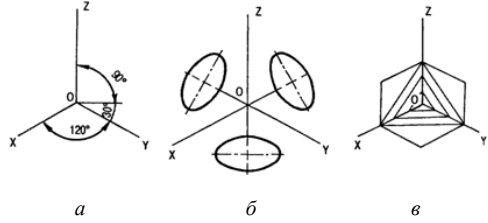

068. " " " " " "
 a - " " " " " " =
 $\bar{\sigma}$ - " " " " " " "XOY, XOZ, YOZ;
 σ - " " " " " " " "

" " " " " " "X, Y, Z "2.: 40
 " " " " " " " " "1,0.
 " " " " " " " " "
 * 1,22 " +0 " " " " " " /
 " " " " " " " " "
 " " " " " " " " " "3.44." "
 " "2.93" " " " "0
 " " " " " " " " " * 069).
 AD." " " " " " " "2.91d." 0 0 /
 " " " " " " " " " "E "F * /
 " " " " " " " " "A D AD)
 "3.44d." " " " " " "0

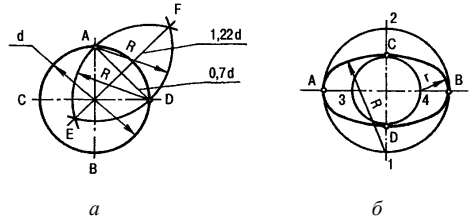

069. " " " " " "
 a - " " " " " " " "
 " " " " " " " " " " " "

" " " " " " " " /
 " " " " " " " " Ø /
 " " " " " " " " Ø " " " " /
 " " " " " " " " ; 2 " " " " /
 " " " " " " " " Ø " " " " /
 "XOY " " " " " Z" " /
 XOZ Y" " ZOY X* 068, б). /
 " " " " " " " " " /
 " " " " " " " " 0 Ø " /
 Ø R " " " " " " " " /
 "*" " " R "+" " " r " " " " /
 " " " " " "*" 069, б). /
 " " " " " " " " 070. /

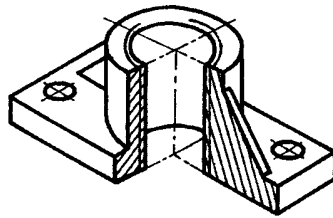

070. " "

2.2.2.

" " " " " " " Z /
 " " " X " 9 " 32 " " Y - " /
 63 47 " " " " " " "*" 071, а). /
 " " " " " " " " " /
 " " " 0 " Y "2.69." " X "Z 0,94. /
 " " " " " " " " " " /
 " " " Ø " X "Z " " " /
 "3.2." " Y - 2.7Ø " " " " " " /
 " " "3.28" Ø " " " " " " /
 " " "XOZ - 0,95d." " "XOY "YOZ 0,35d. /
 071, бØ " " " " " " " " /

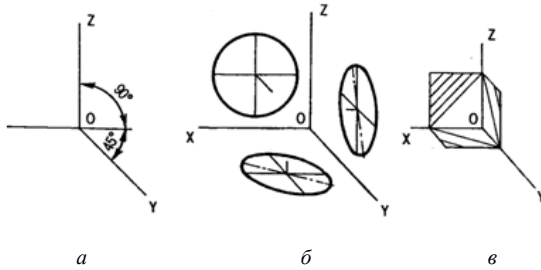

075. " " " " " " : =
a - " ; б - " " " " " " =
в - " " " " " " X "Z "
" " " " " 2.7" " Y.
" " " " " " " "
" " " " " " " " /
" " " " " " " " /
" " " " 075, б). " " " 2.55" " /
" " " " " " 3.29" " " " " " /
" " " " " " " " " " X
9 " 36 " " " " " " " " " " /
" " " " " " " " " " " " /
" " " " " " " " " " " " " " /
" " " " " " " " " " " " " " 0
" " " " " " " " " " " " " " " " /
" " " " " " " " " " " " " " " " " 076.

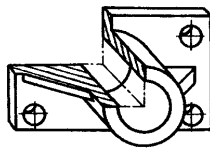

076.

" " " " " " " " " " " " /
" " " " " " " " " " " " " " /
" " " " " " " " " " " " " " " " " /
076.

" "

1. " " " " " A
2. " " " " " " " " " A
3. " " " " " " " " " " "
4. " " " A " A' " " /
5. " " " " A " " " " /
6. " " " " " " " " A " /
7. " " " " " " " " " " " "
8. " " " " " " " " " " A /
9. " " " " " " " " " " " A /
10. " " " A " " " " " " A
11. " " " " " " " " " A' /
12. " " " " A " " " " " " "
13. " " " " " " " " " " " /
14. " " " " 0 " " " " " /
15. " " " " 0 " " " " " "
16. " " " " " A " " " " A'
17. " " " " " A " " " " /
18. " " " A " " " " " " A
19. " " " " " " " " " " " /
- " " " " " " A

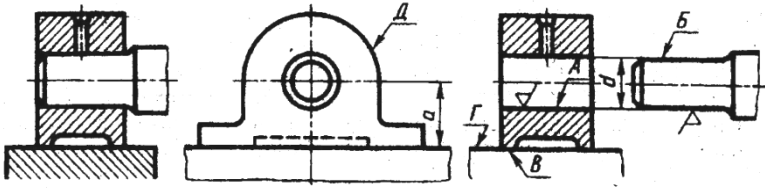

077. " " "A, Б- " "d- " " +=
 Б, Г- " "a- " " ±D-

" " " " " " " " " "
 " " " 0 " " " " " "
 0 " " " " " " " " "
 " " " " " " " " " /
 " " " " " " " " * 078).

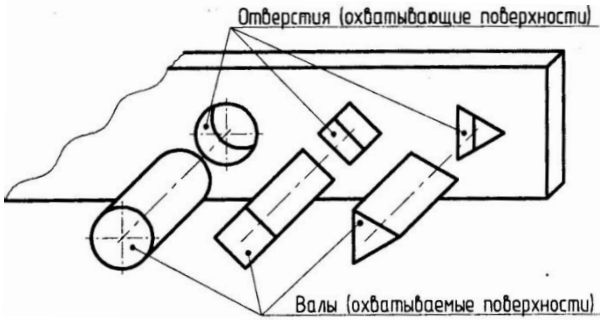

078. " " "

" " " " " " " " /
 " " " " " " " " /
 " " " " " " 0 " " " "
 0 " " " " " " " " "
 0 " " " " " " " " /
 " " " " " " " " " /
 " " " " " " " " " /

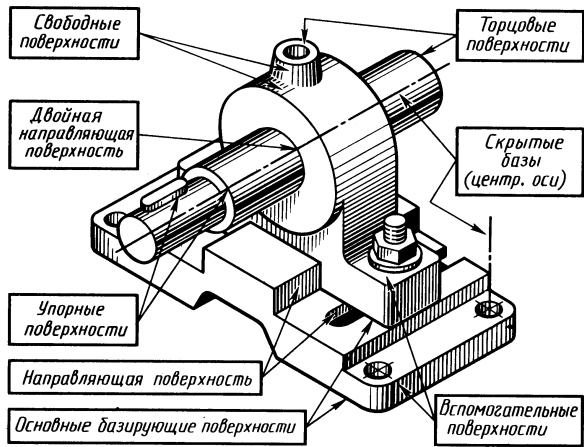

079. " " "

" " " " " " " " " " /

0 " " " " " " " " " " /

" " " " " " " " " " " " 080.

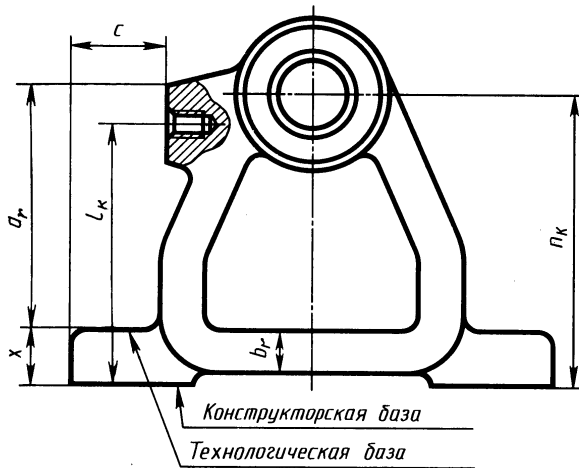

080. " "

" " " " 0 " " - " /
 " " " " " " " " " " "
 " " " " " " * 081, $a \approx 60^*$) "
 " " " " " " " " " " /
 " " " " " " * " " " /
 " " " " " " * 081, θ). "
 " " " " " " " " " " "
 " " " " " " " " " " "
 082 a, $\delta \theta$ " " " " " " "
 " " " " " " " " " " "
 * " " " " " " " " " " /
 " " " " " " " " " " " "
 θ " " " " " " " " /
 " " " " " " " " " * 082, θ). " /
 " " " " " " " " " " 0" " /
 " " " " " " " " " " "
 " " " " " " * 082, a, z, δ).

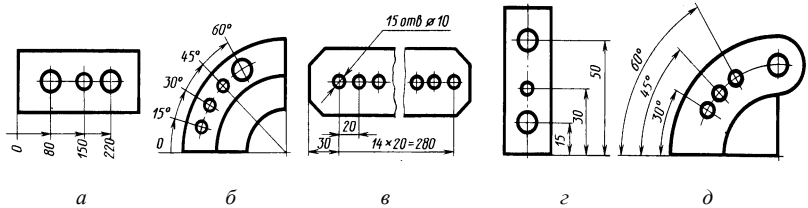

082. " " " " " " " " "
 " " " " " " " " " " "
 * 083, a). " " " " " " " " " " /
 " " " " " " " " " " " " "
 " " * 083, б). " " " " " " " 67 " " "
 " " " " " " " " " " " "
 * 083, a, б " 083, в, z+ θ " " " " " " " "
 " " " " " " " " " " s 0,8 " * 083, z).

" " " " " " " 0 " "

" " " " " 0 " "

8. " " " "

Группа допусков	Допуск	Знак
Допуски формы	Прямолинейности	—
	Плоскости	▱
	Круглости	○
	Цилиндричности	○
	Профиля продольного сечения	≡
Допуски расположения	Параллельности	//
	Перпендикулярности	⊥
	Наклона	∕
	Соосности	⊙
	Симметричности	≡
	Позиционный	⊕
	Пересечения осей	×

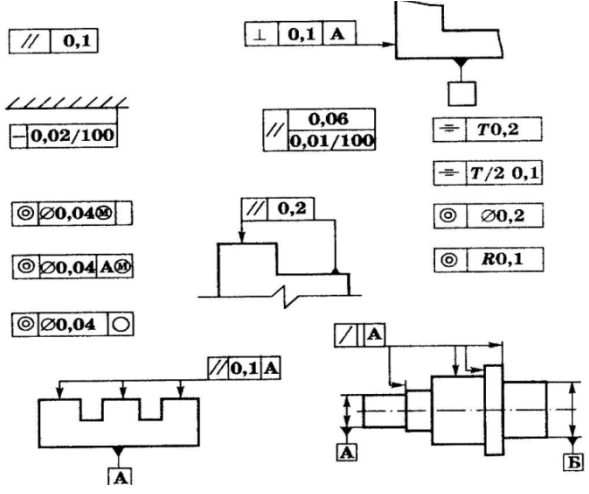

. 86. " " " " " " "

" " " " " " " " " " " " " " " " "

" " " " " " " " " " " " " " " " "

" " " " " " " " " " " " " " " " "

" " " " " * 087±" " " /
 " " " " " 0

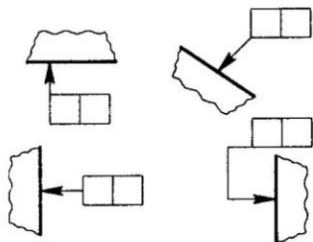

087.

" " " " " " " " Ø /
 " " " " " " " " Ø /
 " " " " " " " " " " /
 Ø " " " " " " " " " " /
 Ø " " " " " " " " " " ,
 " " " * 088).

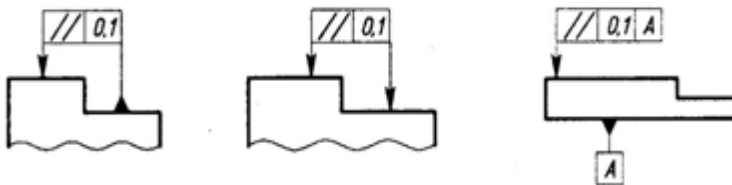

088.

3.3.2.

" " " " " " " " " " /
 " " " " " " " " " " /
 L " " " " " " " " 089. " /
 " " " " " " " " " 0

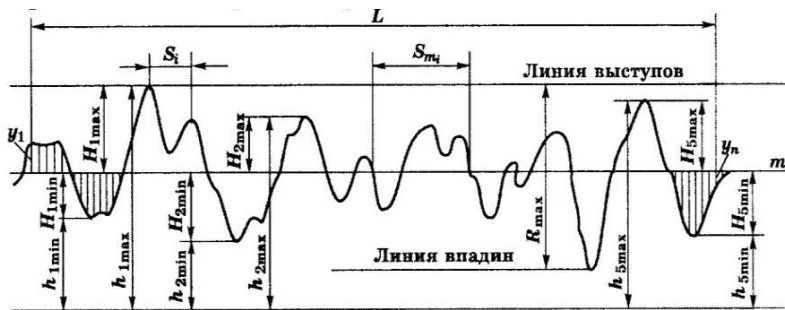

. 89. " " "y_i - " =

$S_i - " = R_{\max} - " " = L - " ;$

$H_{i \max}, H_{i \min} - " " = L - " "$

" " " " " " /

" " " " " " /

R_a " " " " 0 " /

" " " " " " y_i "

" " " " " " "

$R_a = (1 / n + "y_i;$

R_z " " " " " " " 0 " "

" " " " " " " " "

" $H_{i \min}$ " " " $H_{i \max}$ " " " " /

$R_z = "h_{i \max} - " h_{i \min}),$

$h_{i \max} h_{i \min}$ " " " " " " "

" " " " " " ;

$R_{\max} - " " " =$

$S_m - " " 0$

" R_{\max} " S_m " " " 0 " /

" " " " " " " " " /

" " " " " " " 090).

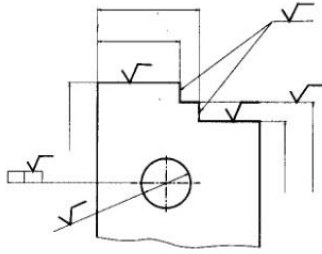

094. " "

" " " R_a R_z " " /
 " " " 2.789 950 R_a " " "
 "322 0,008 0
 " 100; 50; 25; 12,5; 6,3; 3,2; 1,6; 0,8; 0,40; 0,20; 0,10; 0,05; 0,025;
 0,012 0
 R_z " " " 382 0,025 0 /
 " " " "622±422±322±72±47±34.7±8.5±5.4±3.8±2,8;
 0,4; 0,2; 0,10; 0,05; 0,025 0
 " " " " " " " " "
 " " "7 32 " " " " " 095).

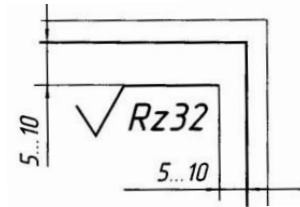

095. " "

" " " " " " " " "
 " " " 0 " " " " " " "
 " " " " " " " " " /
 " " " √, " " " 0 " " "
 " " " " " " 0

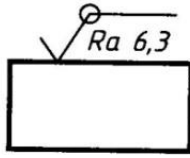

a

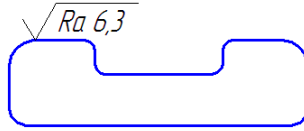

b

0100.

a -

b -

- " " " " " " " " " " " " "
- " " " " " " " " " " " " "
- " " " " " " " " " " " " "
- " " " " " " " " " " " " "
- 1. " " " " " " " " " " " " /
- 2. " " " A " " " " " " " " /
- " " " " " " " " " " " " /
- 3. " " " " " " " " " " " " "
- 4. " " " " " " " " A " " " "
- 5. " " " " " " " " " " " " "
- 6. " " " " " " " " " " " " A "
- 7. " " " " " " " " " " " " " "
- 8. " " " " " " " " " " " " A' /
- " " " " " " " " " " " " "
- 9. " " " " " " " " " " " " /
- " " " " " A' " " " " " " "
- A
- 10. " " " " " " " " " " " A
- 11. " " " " " " " " " " " /
- A
- 12. " " " " " " " " " " " " /
- " " " " A

- 13. " " " " " " A
- 14. " " " " " " A
- 15. " " " " " " " " /
A' " " " " " " A
- 16. " " " " " " " " /
" " " " " " " " ?
- 17. " " " " " " " " A' " "
" " " " " " " " " "
- 18. " " " " " " " " A " " /
?
- 19. " " " " " " " " " " /
" A' " " " " " " A
- 20. " " " " " " " " " " /
" " " " " " " " "
- 21. " A " " " " " " " " /
" " " " " " A " " " "

3.4. " " " " .

" " " " " " " " " " /
" " " " " " " " " " " " /
" " " " " " " " " " " " " " /
" " " " " " " " " " " " " " /
" " " " " " " " " " " " " " 0 /
" " " " " " " " " " " " " " /
, " " " " " " " " 0

3.4.1. " " " " " " " " " " .

" " " " " " " " " " " " " " /
" " " " " " " " " " " " " " , " /
, " " " " " " " " " " " " " " " " /
" " " " " " " " " " " " " " " " " /

" " " " " " " " 0 "

" " " " " " " " "

" " " " " " " " "

" " " " " " " " /

0 " " " " " " /

" " " " " " " "

" " " " " " " "

" * 0101).

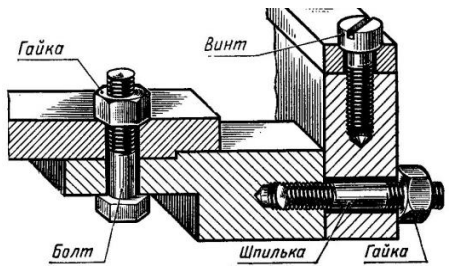

0101.

" " " " " " " " "

" " " " " " " " /

" " " " " " " " "

" " " " " " " " * 0102, а).

" " " " " " " " /

" " " " " " " " " 0 0* 102, б).

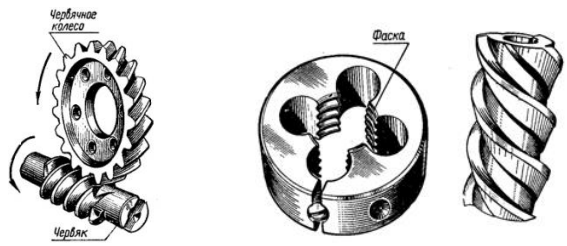

а

б

0102.

б

" " 55.46; \emptyset " " " " "
 " " " 0 " " " " " " "
 " " " " " " " " 012.
 12. " " "

	"	"	"	"	"
	"	"	"	"	"
1/4	9	19	1,337	13,157	13,5
3/8	10	19	1,337	16,667	17,0
1/2	15	14	1,814	20,955	21,3
3/4	20	14	1,814	26,442	26,8
1	25	11	2,309	33,249	33,5
1 ^{1/4}	32	11	2,309	41,912	42,3
1 ^{1/2}	40	11	2,309	47,805	48,0
2	50	11	2,309	59,616	60,0
2 ^{1/2}	70	11	2,309	75,187	75,5

" " " " " " " " " " "
 " " " " " " " " " " "
 " " " " " \emptyset " " " " "
 " " " " " " " " " " 1:16.
 " " " " " " " " " " \emptyset " "
 " " " 0 " " " " " " "
 " 0 " " " " " " " " "
 $R_c \emptyset$ " $R^{1/2}, R_1^{1/2}LH, R_c^{3/4}LH \emptyset$ " " " "
 " " " " " " " " " "
 " " " " " " " " " "
 " " " " " " " " " "
 " " " " " " " " " "
 (0 0107, \emptyset^H " " " " "
 * 0 . 107, \emptyset). " " " " "
 0 " " " " * 13536 68) " -
 " " * " " " 34 \dagger " " "
 * 13556 68) " " " " "
 " 0 " " " 12 4.76"
 13536 8: " 34 " " " 4.76 " - ;
 "Rd20, Rd16LH."

" " " Tr40 6-8e." "62" -
 " " "8"- .8e - " Ø " "
 "Tr40 9(P3)LH-6e." "40 - " " ;"- .5 -
 " " "LH - " "6e - " Ø " " "
 " " " " " Ø " " "
 " " " " " 0 " " " "
 " " " " " " "52° "5° (0 0107, e).
 " " " " " " " 10177 82.
 " " " " " " " " "
 " " " " " Ø " : S60 8-7h;
 S60 12LH-7H; S60 12(P3)-7h; S80 20(P5)LH-7h. "
 " " " " " " 0

3.4.1.4.

" " " " " " " "
 Ø " " " " " " " "
 " " Ø " " " " " " "
 " " " " " " " " " "
 " " Ø " " " " " " "
 Ø " M21 1.7"* " "+" "M20 3,4
 * " "+" Tr33 2 (" " "
 " " "+" S37 19,5(P6,5)LH (" , "
 +0 " " " " " " " "
 " " " " " " * 0 0107, жс).
 " " " " " " " " " "
 " " " " " " " " " Ø
 " " " " " " " " " 0
 " " " " " " " " " Ø
 " " " " " " " " " "
 " * 0109, а). " " " " " "
 " " " " " " " " " "
 * 0109, б).

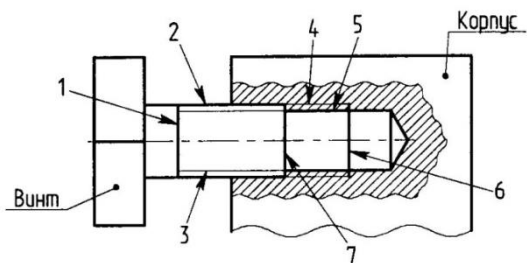
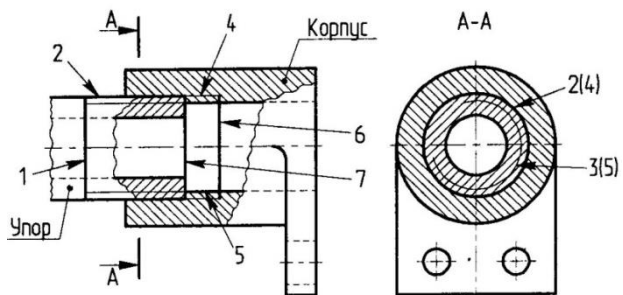

0115. " " "I - " " "*" +=
 2 - " " " " " " " =
 3 - " " " " " " " =
 4 - " " " " " " "*" + =
 5 - " " " " " " " =
 6 - "*" " " " " " " " =
 7 - " " " " " "*" " +

" " " " " * " + " "
 " " " " " " " " " " " "
 " " 0 0 " " " "*" 0116).

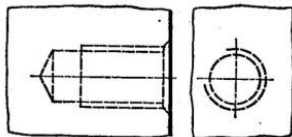

0116. "

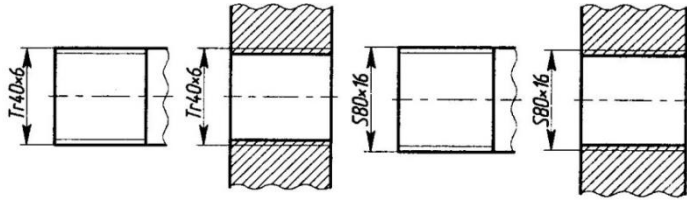

б

в

0118. " " "а - " =
 б - " =8 -

" " " " * 0119, а) " "
 " * 0119, б) " " " " -
 " " " " " 0

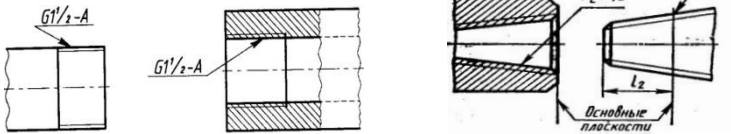

а

б

0119. " " " " " "
 а - " =б -

" " " " " " " " " "
 " " " * " + " " " " " " " " " "
 0

3.4.2.

" " " " " " " " " "
 " " " " " " " " " * +0
 " " " " " " " 55 87 % " 0
 " " " " * " " " " +
 0 " " " " " " " " " "
 " " " " " " " " " " " "

	"	"	"	"	"	"	"	"	"
	"	"	"	"	"	0	"	"	"
	"	"	"	"	"	"	"	"	"
	"	"	"	"	1d; 1,25d; 1,6d; 2d; 2,5d.	"	"	"	"
	"	"	"	"	M20 1,5 6q 322Ø: Ø57"	22032 98	"	"	"
	"	"	"	"	"42	"	"	"	"
1,5	"	"	"	6q.	"	322	"	"	"
	70.	"	-	"	"	7	0	"	"

3.4.2.4.

"	"	"	"	"	"	"	"	"	"
"	"	"	"	"	"	"	"	"	"
		"	"	"	"	"	"	"	0
0126Ø	"	"	"	"	"	"	"	"	"
"	"	"	"	"	"	"	0	"	"

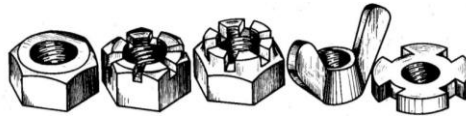

0126.

"	"	"	"	"	"	"	"	"	"
"	"	"	"	0127.	"	"	"	"	"

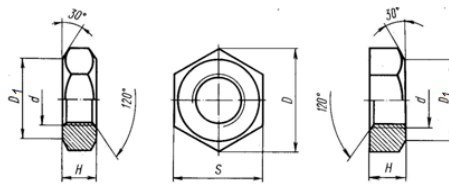

a

б

d	0127.	"	"a	1; б	2;	=
	"	=D	"	"	=H	
		S	"	=D ₁ = 0,95S		

" " " " " " " " " " 2
 " " " " " " " " " " "
 " " " " " " " " " " "
 " 0127 " " " " " " " " "
 " " " " " " " " " " "
 "* 0128).

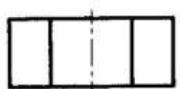

a



b

0128. "
 a = b

" " " " " " " " H = 0,6d;
 " " H = 0,8d± " " H = 1,2d± " " H = 1,5d.
 " " " " " " " " 0
 * " " ± " " " " " " "
 * " ± " " " " " " " " "
 " " " " " " " " " " "
 " " " " " " " " " " "
 " " " " " " " " " " "
 " " 32 * " 6" · 10 = 40 1 2+0 " "
 " " " 2M12 1,5 6 H08402 098 5915 92 "
 " " " " " " " " " 34 " "
 " " 1,5 " " " " 6H." " 12, "
 " " " 62 " " " " " "
 9 0 " " " " 5915 920 " "
 " " M10 6H08" 5927 92 " " "
 " 3." " " " " 32 " "
 " " 6H." " " 8." " " "
 5927 70, " " " " 0
 " 014 " " " " " " 0127.

14. "

"d	S7025C	5915 70	"	5927 70
----	--------	---------	---	---------

" " " " " " , "

" " 0130).



a

б

в

г

0130. " "a "(); δ ();
 " " " " " ") ; ε ()

" " " " " " " " " "

" " 015.

15.

	11371 78				6402 70	
	<i>d₁</i>	<i>d₂</i>	<i>s</i>	"	<i>d</i>	<i>b</i>
6	6,4	12,0	1,0	0,3	6,1	2,0
8	8,4	15,5	1,6	0,4	8,1	2,5
10	10,5	18,0	1,6	0,4	10,1	3,0
12	13	21	2,0	0,5	12,1	3,5
14	15	24	2,0	0,5	14,2	4,0
16	17	28	2,0	0,5	16,3	4,5
18	19	30	2,5	0,6	18,3	5,0
20	21	34	2,5	0,6	20,5	5,5
22	23	37	2,5	0,6	22,5	6,0
24	25	39	2,5	0,6	24,5	7,0
27	28	44	2,5	0,6	27,5	8,0
30	31	50	3,0	0,8	30,5	9,0
36	37	60	3,0	0,8	36,5	9,0
42	43	72	4,0	1,0	42,5	10,0

" " " " " " " " "

" " " " " " " " "

+ " " " * " " + " " "

" " " * 23 " 24 " 33 " 54 + " " " "

" " " " " 0 " " " " " "

11371 9: 0 " " " " " " 2.14.01.099

" " " " ,

4." " " " " 36 " " " "
 23"* " " " " " 2; "*" " " " "
 9 " " " " 11371 78. " " " " "
 " " " " " " " " " " "
 " " " " 0 " " " " " "
 " " " " " " "*" "+" " "*" "+" " "*" "+" "
 " "*" "+" " " " " " " " " "
 12 87 Ø5;" 6402 92 " " 34 " 87 Ø48"
 6402 92 0 " " " " " " "
 " " " " " 34 " " " "*" " " " "
 "+" " " 87 " 03 * - "+" " " " "
 9 " " " " 6402 920 " " " " " "
 " " " " " " " " " " *24+" "
 "8 0

3.4.2.6.

" " " " " " " " " "
 " " 0 " " " " " " " "
 " " 0 " " " " " " " " 0131.

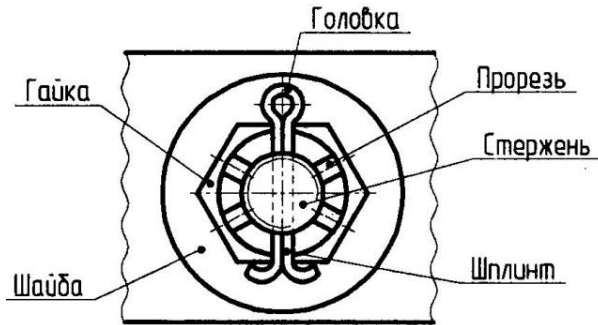

0131. " "

" " " " " " " " " "
 " " " " " 0 " " " "
 0132." " " " " " " 016.

" " " " " "

* 0135).

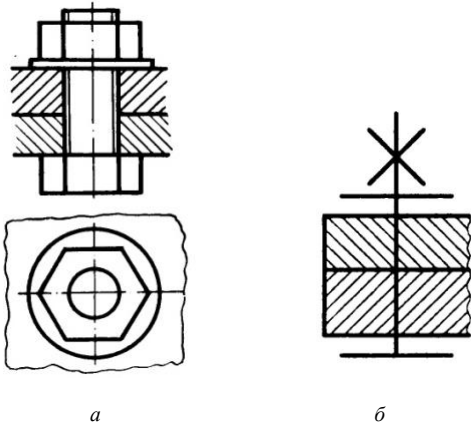

0135. " " " " " "

a =b

" " " " " " " " " " " "

" " " " " " " " " " " "

" " " " " " " " " " " "

" " " " "4 0 " " " " " "

" " " " d." " " " " " "

" l " " " " " " " " " "

" " " " " " " " " " " "

3.4.3.2. "

" " " " " * " " + " "

" " " " " * 0136). " " "

" " " " " " " " " "

∅ " " l₀ "l₂ " " . 136, a.

- " "
1. " " " " " 0 " " A'
 2. " " " " " " " " " A'
 3. " " " " " A " " " "
 4. A " " " " " " " A "
 5. " A " " " " " " " "
 6. " " A " " " " " A' "
 7. " " " " " " A " " " " "
 8. " " A " " " " " " " "
 9. " " " " A' " " " " " "
 10. " " " " " " " " " " "
 11. " " " " " " " " " ?
 12. " " " " " " " A

3.6. "

" " " " " " " " /
 " " " " " " " " 0
 " " " " " " " " " "
 " " " " " " " " " "
 " " " " " " " " 0 " "
 " " " " " " " " " "
 0 " " " " " " " " "
 " " " " " " " " " "
 " " " " " " " " * † " "
 0 " " " " " " " " " "
 " " " " " " " " " "

" " " " " " " " /
 " " " " " " " " /
 " " " " " " " " t.
 " " " " " " " " " 0 σ
 " σ " " " " g (0 0151). /
 " " " " " " " " " "
 " k." " " " " * 0 0151). "
 " " " " " " " " "
 " " " " " " " " " /
 " " " " " " " " " /
 " " " " " " " " " 3." 4."
 5." , " 3." . 3." " 3." " 0 0 " " /
 " " " " " " 0 "
 " " " " " " " " " "
 " σ " " " " " " " " "
 " " " " " * . 154, a).

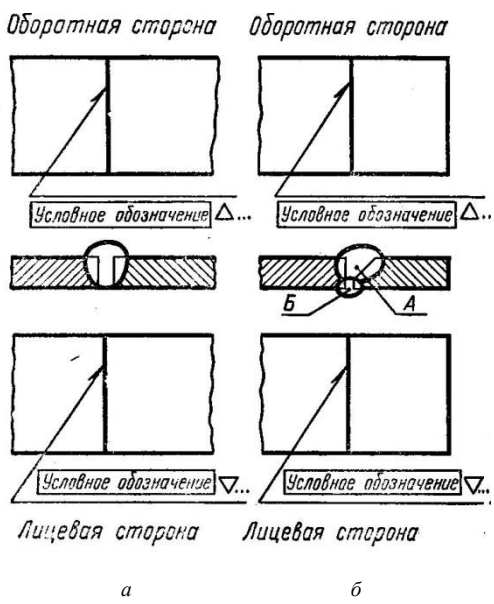

0154. " " "
 а " =б " "
 (А " =Б " +

" " " " " " " " /
0
" " " " " " " "
" " " " " " * 0157, a, б).

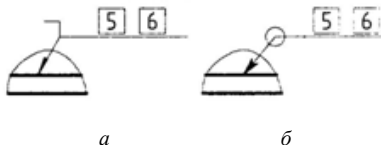

0157.
a " " =б "

" " 7" "8" " " " " " "
σ " " " * " " " "
" " " " 0 0" " " " "
" " " " 0 " " " "
" " " " * 0158).

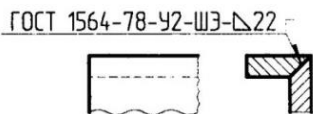

0158. " "

" " " " " 0158 " " " "
" " " σ " " " 1564 78
" " " " 0 " " " 44 σ "
" 0159 " " " " 0 " 0



0159. " "

" " " " 0 " " " " " " " /
 " " " " " " " " " " /
 " " " " " " " " " " " " " /
 " " " " " " " " " " " " " /

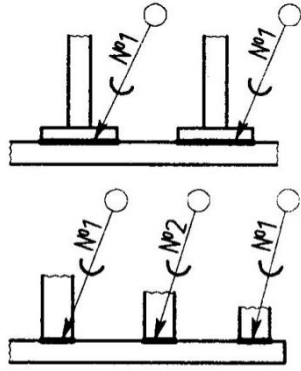

0162. "

" " " " " " " " " " /
 " " "58" * 3+ " "62" * 4+ " 0 0 " " /
 " " " " " " " " " " " " " /
 " " " " " " " " " " " " " /

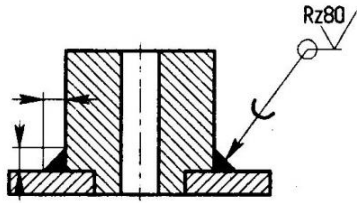

0163. "

" " " " " " " " /
 - " -; 2+ -52+ -3: + "6-8+ "47-2;
 " 61-27+ - " "58+ "6: + "76+ /
 " "47+ "67" " 0

19249 73.

"	"	"	"	"	"	"	"
"	"	0	"	"	"	"	/
"	"	"	"	"	"	"	/
0	"	"	"	"	"	"	/
"	"	"	"	0	"	"	"
"	"	"	"	"	"	K*	0164, a, б).

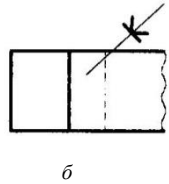
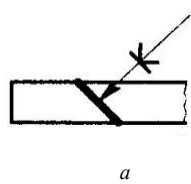

0164. "

"	"	"	"	"	"	"	/
"	-	"	"	"	"	"	"
"*	0164, б).	"	"	"	"	"	"
"	"	"	"	"	"	"	"
"	-2	"	*	1).	"	"	/
"	"	"	"	"	"	"	"
"	"	"	"	0	"	"	"
"	"	"	"	"	"	"	"

1. " " " " " " A' " /
2. " " A A " " " "
3. " " " " " " " " "
- A
4. " " " " " A " " " /
5. " " " " " " " " " "
6. " " " " " " " " " A " A
7. " " " " " " " " " " A /

8. " " " " " " 0 "
9. " " " A " " " " " " " /
10. " " A " " " " " " A' /
11. " " " " " " " " A' " "
12. " " " " " " " " " A' "
13. " " " " " " " A " " " A "
14. " " " " " " " " " " "
15. " " " " " " " A " " " " /
16. " " " " " " " " " " A
17. " " " " " " , " " " " /
18. " " " " " " - " " " " /
19. " " " " " " " " - A " "
20. " " " " " * " # " " "
21. " " " " " " " " " " /

3.7. " " 0

" " " " " " " " /

" " " " * " # " " " " /

" " " " " " " " " " " "

" " " " " " " "[1, 2, 4, 5] " " "

" " " " " " " 0 " "

" " " " " " " " " "

" " " " " " " " " "

" " " " " " " " " "

" " " " " " " " " "

" " " " " " " " " "

" " " " " " " " " " /
 " " " " " " " " " " "
 " " " " " " " " " " "
 * " " " " " " " " " " "
 " " " " * " " " " " " /
 " " " " " " " " " " "
 " " " " " " " " " " "
 " " " " " " " " " " /
 " " " " " " " " " " /

0165.

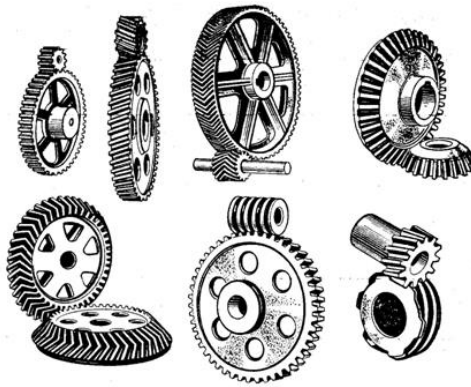

0165.

" "

" " " " " " " " " " "
 " " " " " " " " " " "
 0 " " " " " " " " " " "
 " " " " " " " " " " "

0166.

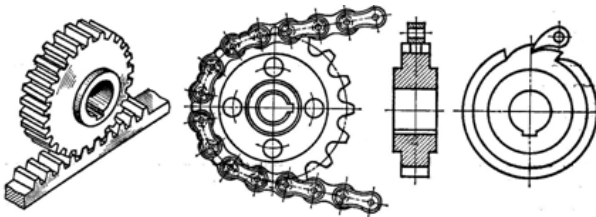

a

b

c

0166.

"a

=b

=c

" " " " " " " " " " /
 " " " " Ø " " " " " /
 " 0 " " " " " " " " /
 " " " " " " Ø " " " " "
 " " " " " " 0 " " " "
 " " " " " " " " " "
 " " " " " " 16531 83. " " "
 " " " " " " " " 16530 83.

3.7.1.2.

" " " " " " " " " " * 0168).
 " " " " " " " " " " /
 " " " " " " " " " " /
 0

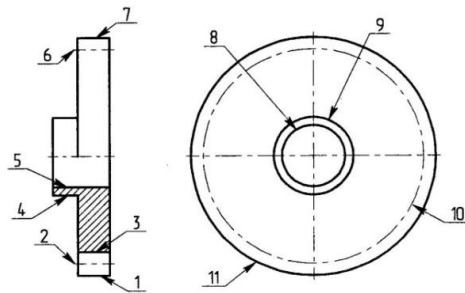

0168.
 1, 2, 4, 11
 1, 7, 3
 4, 5, 8, 9
 6, 10

" " " " " " " " " " /
 " " " " * " + " " " " " /
 Ø " " " " " Ø " " " " " "
 " " " " " " " " " " " "
 " Ø " " " " Ø " " "

3.7.1.4.

" " " " " "

" " " " d_a " " " b "

" " " " " * " " " /

" " " " σ " " " " /

" " " " σ " " " " " /

" " " " " " " " 0 " " /

"42 " " " " " " " " 2.403 75.

" " " " m " " z " " " " d ,

" " " " 1643 81 " " 9178 : 30 " "

" " " " " " σ " " " /

" " " " " " 0173.

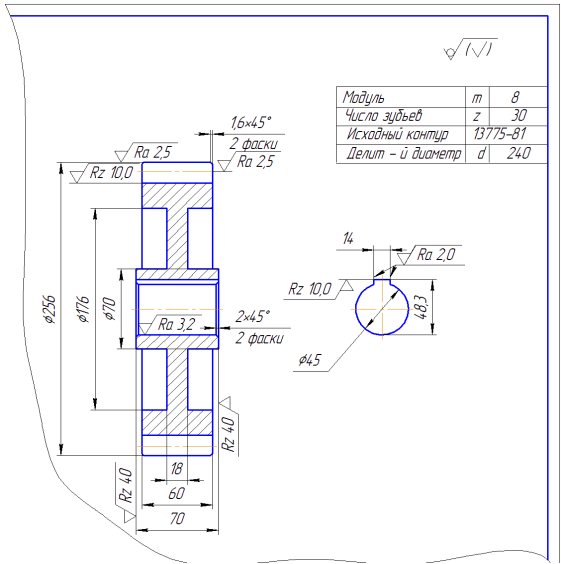

0173.

" " " " E " " " " Ø " "
 " " " " " " " " E " B "
 " BC " Ø " CE " " " " "
 " " " " " Ø " " " " "
 NS.

" "

1. " " " " A' " " " A "
2. " " " " " " " " A' /
3. " " " " " " " " " " /
4. " " " " " A " " " 0 "
5. " " " " " " " A' " A "
6. " " " " " " " " " "
7. " " " " " " " " " " "
8. " " " " " A' " " " A " A'
9. " " " " " A " " " " " /
10. " " " " " " " A " " " A'
11. " " " " " " " " " " "
12. " " " " " A " " " 0 " "
13. " " " " " " " A' " " " "
14. " " " " " " " A " " " /
15. " " " " " " " " " " " /

Ø " " " " " " " " " /
 " " " " " " Ø " " " " " /
 " " " " " " " " " " 020.
 Ø " " " " " " " " " "

20. " " " "

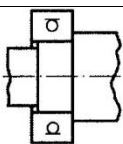
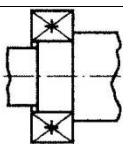
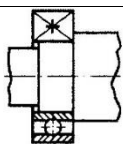
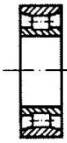
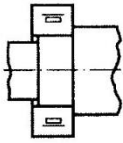
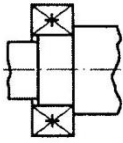
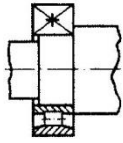
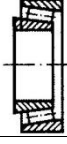
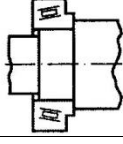
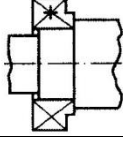
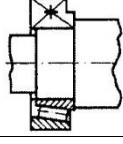
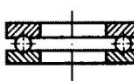
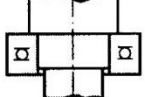
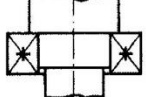
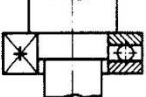
"	" "		
	" "	" "	" "
1.	"	"	8338 75)
			
2.	"	"	8338 75)
			
3.	-	"	8328 75)
			
4.	"	"	7872 80)
			

" " " " " " " " " "
 " " " " " " " " " /
 " " " " " " " " " "
 Ø " " " " " " " " " /
 " " " " " " " " " " 0 " " " /

0 " " " " " " ; " " " " /

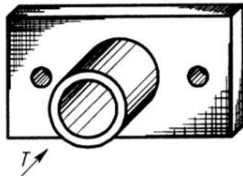

a

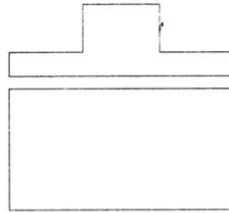

б

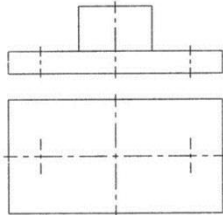

в

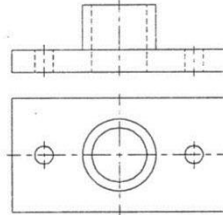

г

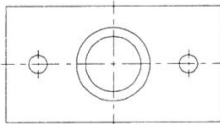
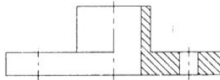

д

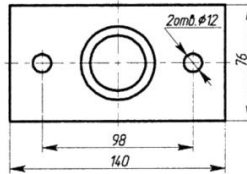
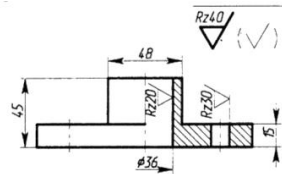

е

0184.

" "

3.9

6qx: 20 32; 03: " 7798 70 , M12-6H07" 5915 70 ,
 8 7 62" 23360 78 " 0 00 " " " /
 " " " " " " " " " " /
 " " " " " " " " " " 0 0 " " "
 " " " " " " " " " " " " "
 " " "(M8 , M: " 0). " " " "
 " " " " " " " " " " " " "
 " " " " " " " " " " " " 0 "
 " " " " " " " " " " " " "
 " " " " " " " " " " " " /
 " " " " " " " " " " " " /
 " " " " " " " " " " " " 0 "
 " " " " " " " " " " " " 0 "
 " " " " " " " " " " " " /
 " " 0189.

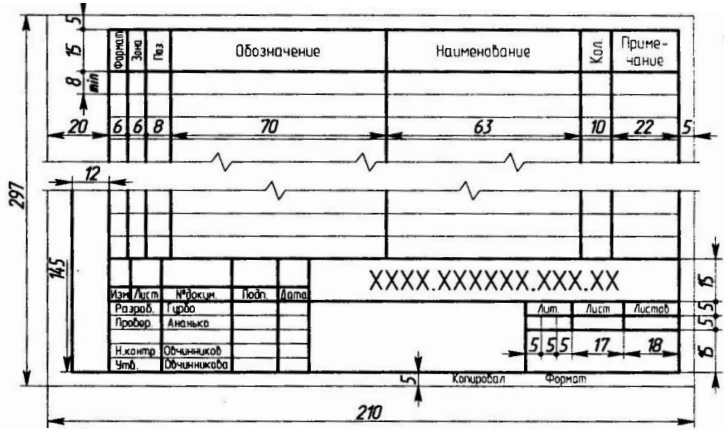

0189. " " 2.106 96

" " " " " " " " " " "
 " " " " " " " " " " "
 " " " " " " " " " " /
 0 " " " " " " " " " " /

6. " " " " " " " " /
 " " " " 0 " " " " " /
 7. " " " 0 " " " " " /
 8. " " " " " " " " " "
 " " " " 0 " " " " " "
 9. " " " " " " " " " "
 " 0; " " " " 0 " " " " "
 10. " " " " " " " " " " /
 " " " " " " " " " " 0
 11. " " " " " " " " " " /
 " " " " " " " " " " 0 /
 12. " " " " " " " " " " /
 " " " " " " " " " " "
 " " " " 0 " " " " " "
 13. " " " " " " " " "4 " " " /
 " " " " " " " " " " /
 " " " " " " 0 " " " " " "
 14. " " " " " " " " " " " "
 " " " " " " " " " " 0
 15. " " " " " " " " " " " /
 " " " " " " " " " " "0 0 " "
 0 " " " " " " " " " "
 " 0;" " " " " " " " " " "
 16. " " " " " " " " " " " /
 " " " " " " " " " " " "
 , " " " " " " " " " " 0
 17. " " " " " " " " " " " "
 " " " " " " " " " " " "
 0 " " " " " " " " " " "
 18. " " " " " " " " " " " "
 " " 0 " " " " " " " " "
 19. " " " " " " " " " " " "

2.316 68.

0190.

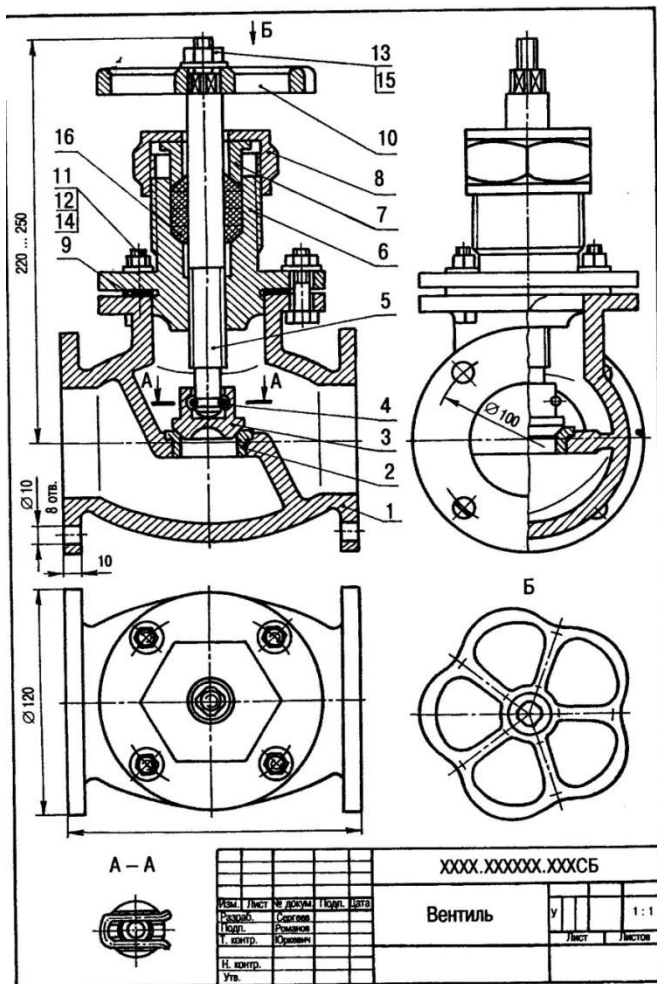

0190.

" " " " " " " " 0191.



Экспликация

№	Наименование поз. зданий и сооружений
1	Учебный корпус
2	Спортзал
3	Паркинг
4	Мастерская учебная
5	Летняя кухня
6	Мастерская
7	Общжитие №1
8	Общжитие №2
9	Котельная
10	Тур
10	Басильевская площадь
11	Городицкая площадь
12	Воскресенская площадь
13	Станция аэротранса
14	Открытый склад

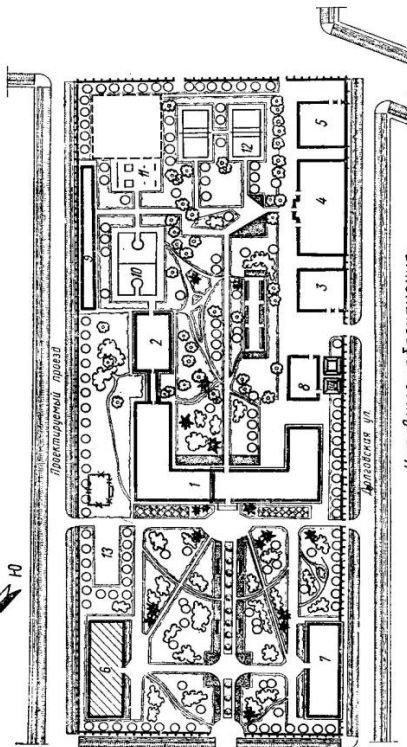

Условные обозначения:

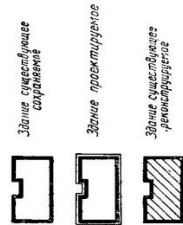

Здание существующее
сооруженное

Здание проектируемое

Здание существующее
демонтажное



Зеленая существующая
рекреативная

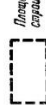

Площадка резервная для
строительных работ



Площадка аэродромного
службы милиции



Существующие деревья



Новые посадки березы



Хвойные деревья. Новые посадки



Кустарники



Шпалы. Забор. Изгородь

0193.

" "

" "

4.2.

" " " 0

" " " " " " " " /

" " " " " " " " " "

" " " " " " " " " " /

" " " " " " " " " " /

" " " " " " " " " " /

" " " " " " " " " " 0

" " " " " " " " " " *

" " " " " " " " " " 0194).

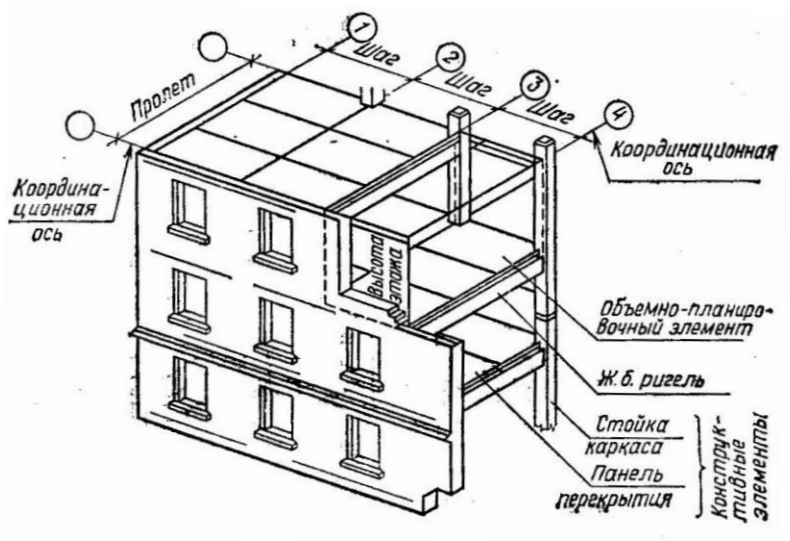

0194.

" " " " " " " " " "

" " " " " " " " " " /

" " " " " " " " " " *

" " " " " " " " " " 0195).

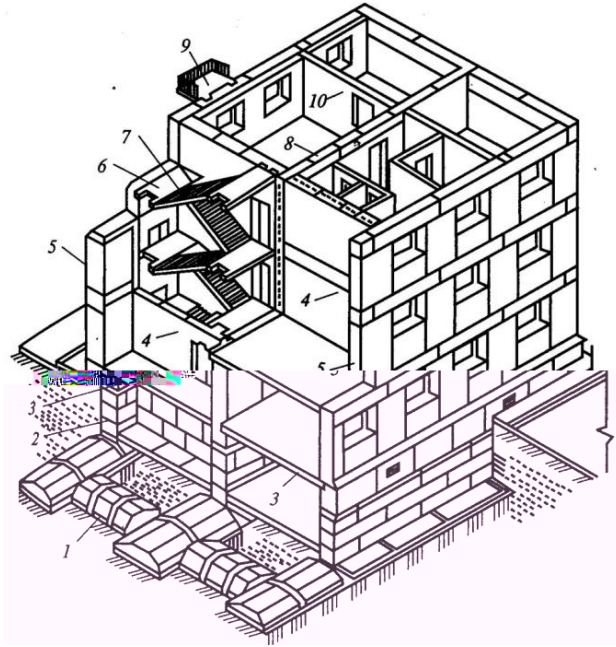

0196. " " "1 =2 " " =
 3 =4 " =5 " " =
 6 9 =7 " ;8 " " =
 =10 " "
 " " " " " " /
 " " " " " 0 0* 0 0194). " "
 " " " " " " " 0 "
 " " " " " " "322 " /
 " 0 " " 0 0 " " " , /
 " " " " " " 0 " "
 " " * " † " "
 6 000, 3 000, 1 500, 1 200, 600, 300 0 " "82 "52 "
 37 "34 "8 "5 0 " * † 50, 20, 10, 5, 2, 1 0
 " " "314 "317 "3132 "3142 "3172 "31322 0

" " " 1:100, 1:200, 1:400. " " /
 " " " " Ø " " /
 1:50, 1:25, 1:42Ø " " " " " "
 " " " " 2.305 68. " " /
 " " " " " " " " /
 " " " " " 0 Ø " " " /
 " " " " " " " " "

4.3.3. " "

" " " " " " " " " " Ø
 " " " " " " " " " " " "
 " " " " " " " " " " " "
 " " " " " " " " " " " "
 " " " " " " " " " " " " /
 " " " " " " " " " " * 0201).

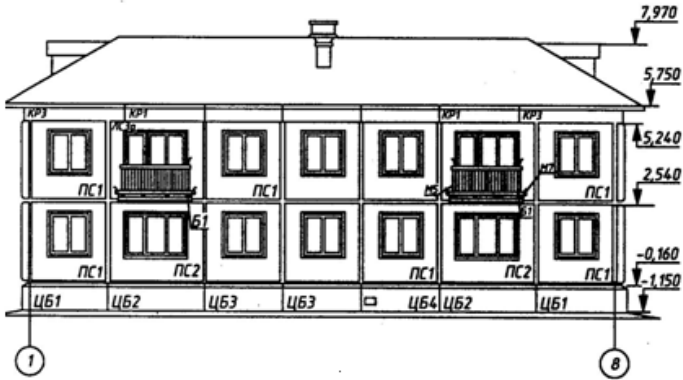

0201. "3 : " "

" " " " " " " " " " /
 " " " " " " " " " " "
 " " " " " " " " " " "
 " " " " " " " " " " " " 0 0

- " " " " " " " /
- ;
- " " " " " " "T-FLEX PLM;
- " " " " " " 0

5.3.1.3.

" " " " " " " " " /
 "*" " " " " " " " " 0 /
 " " " " " " " " " " " " /
 " " " " " " " " " " 0

PTC Creo.

"4 "5 " " " " " /
 " " "PTC0 " " " " /
 PTC Creo " " " " " " /
 0

- " " " " " " " " ;
- " " " " " " " " /
- ;
- " " " " ;
- " " " " " " " " /
- " " " " " " " " /
- " " ;
- " " "RNO - "PTC Windchill.

NX.

NX

PLM Software " " " " " " " Siemens /
 " " " " " " " " " /
 " " " " " " 0

- " " "NX: " " "UNIX, Linux,

Mac OS "Windows;

- " " " " " " " " "
- " " ;
- " " " " " " ;
- " " " " " " "*" "

"

1. " 0 0 " 1" 0 0 0 " /
 "42280 336 0

2. " 0 0 " " " " 1" 0 0 "
 0 0 " 0 0 0 " 0 " " "42250 320 0

3. " 0 0 " " " 1" 0 0 " 0 0 /
 " 0 0 " 0 0 0 0 6- 0 :

- "42290 456 0

4. " 0 0 " " 0 " 1" 0 0 "
 0 0 0 " " "42340 552 0

5. " 0 0 " " " "
 " 1" 0 0 0 6- 0 : 0 "4226. 435 0

6. " 0 0 " " " " 1" 0 0 0
 " " "42260 320 0

7. " 0 0 " " " " " "
 " - " " -3D "4 01" 0 0 0 " "

2001. 01. 312 0

8. " 0 0 " " " " " "
 0 0 " 0 0 " 0 0 0 " " "42340 264 0

9. " 0 0 " 0 " " " " 0
 " " " 1" 0 0 0 0 " 0 0 0
 " "4236. 50 0

10. " 0 0 " " " " " "
 " " " " " " " "
 0 0 " 0 0 0 " "4239. 48 0

"

2.001 ; 5" 0 " . 0 " " " 0
 2.004 88 " " 0 " " " " 0
 " " " " " " " " 0

2.051 42280 " 0 " " 0
 2.052 42280 " 0 " " 0

2.101 8:" 0 " 0 " " 0
 2.102 8:" 0 " " " " 0
 2.104 8:" 0 " 0 " " 0
 2.108 ::" 0 " " 0
 2.109 95" 0 " " " 0
 2.114 ; 7" 0 " 0
 2.301 8:" 0
 2.302 8:" 0 0
 2.303 8:" 0 0

3.4.1.5.	" " " " "	96
3.4.1.6.	" " " "	101
3.4.2.	"	102
3.4.2.1.		103
3.4.2.2.		106
3.4.2.3.		107
3.4.2.4.		108
3.4.2.5.		110
3.4.2.6.		112
3.4.3.	"	113
3.4.3.1.		113
3.4.3.2.	"	115
3.4.3.3.	"	116
3.5.	"	118
3.5.1.	"	119
3.5.2.	"	122
3.5.3.	"	126
3.6.	"	127
3.6.1.	"	128
3.6.1.1.	" " " "	132
3.6.1.2.	" " " " " "	134
3.6.2.	" " " " " "	136
3.7.	" Ø " " " "	140
3.7.1.	"	142
3.7.1.1.	" " " Ø " "	142
3.7.1.2.	" " " " "	144
3.7.1.3.	" " " " "	145
3.7.1.4.	" " " " " "	148
3.7.2.	"	149
3.7.3.	"	152
3.8.	" "	155
3.8.1.	"	156
3.8.2.	"	158
3.9.	" " "	159
3.9.1.	"	160
3.9.2.	" "	162
3.9.3.	" " "	164
3.9.4.	Ø " " "	164
3.10.	"	168
3.10.1.	" " "	169
3.10.2.	" " "	169
3.10.3.		171
3.10.4.	" " " "	173
3.10.5.	" " " " "	175
3.11.	-	179
4.	" "	184
4.1.	"	184
4.2.	" Ø " "	186
4.2.1.	"	190

4.3.	"	192
4.3.1.	" " " " " Ø "	192
4.3.2.	"	193
4.3.3.	"	195
4.3.4.	" " " "	196
5.	"	202
5.1.	"	203
5.2.	" " " Ø " "	204
5.2.1.	" " " " "	207
5.3.	" " - " "	207
5.3.1.	" " " " " "	207
5.3.1.1.	" " " " " "	208
5.3.1.2.	" " " " " "	209
5.3.1.3.	" " " " "	212
5.3.1.4.	" " " " "	213
5.3.2.	" " " " - . "	214
5.3.3.	" " -3D	219
	"	224